

IN FOCUS: Pumps

Issue 1, Spring 2013

Contents



Belzona Solutions for Pumps 1

Increasing service life and saving costs...



Independent Fluid Flow Testing 2

Tough Against Wear 3

Service life of 10 vacuum pumps increased by a factor of 6...

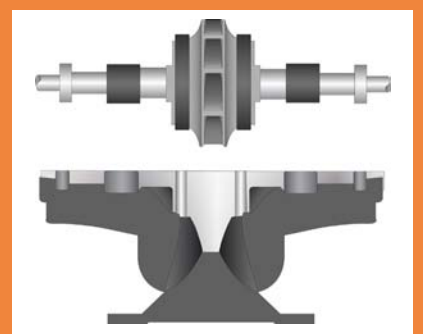

Going with the Flow 4

Flow rate increase in centrifugal pump maintained at 9.5% after 3 1/2 years in service...

BELZONA SOLUTIONS FOR PUMPS

The process of pumping fluids and solids puts equipment under constant strain. The consequence: corrosion and erosion processes occurring on main pump components such as impellers, casings and shafts. Cutwaters, wear rings and housings need to be monitored before they cause major problems with regards to the functioning and performance of the pump.

Initially, damage will lead to rough and pitted surfaces, which will increase friction and lead to a drop in the efficiency of the system as well as increased running costs. However, if not tackled in time, corrosion-erosion problems may jeopardise the integrity of the component, ultimately causing failure of the equipment.

While replacement might be an obvious solution, it is usually associated with high costs and lead times of weeks or even months. Hot work including welding and weld overlay, on the other hand, can induce heat stresses into the equipment and create problems with galvanic corrosion. More importantly, however, neither solution will address the underlying problem. For this reason, an increasing number of pump operators are turning to cold-curing polymer technologies to repair and protect their equipment.

Increasing service life & saving costs

Belzona systems provide a simple and cost-effective way of restoring the original profile and protecting components from future damage, while ensuring that the equipment is back in service in a matter of days. Application will result in a pump that is better than new, offering increased erosion/corrosion resistance and improved performance.

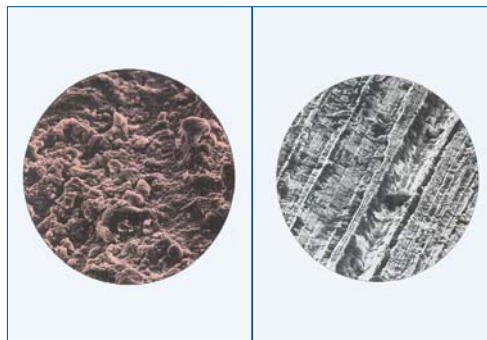

Even seemingly smooth metal surfaces are found to be relatively rough when examined under high magnification...

Repair

The Belzona range includes a selection of paste grade materials designed to offer repair solutions for a large variety of application situations.

Belzona 1111 (Super Metal) is the so-called “workhorse” of the range. Like all Belzona materials for pump repairs, this multi-purpose repair composite offers outstanding corrosion resistance, moulds to precise contours and can be applied in thin or thick sections in one operation. It bonds strongly to any metal substrate and will not shrink, expand or distort during the curing process – a significant advantage over composites that contain volatile organic compounds.

In many instances where the substrate has been affected by severe erosion-corrosion, Belzona 1311 (Ceramic R-Metal) is the first choice for repairing wear and restoring the

INDEPENDENT FLUID FLOW TEST BY THE BRITISH NATIONAL ENGINEERING LABORATORIES (N.E.L.):

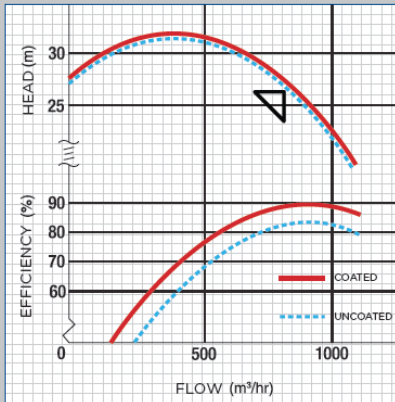

For this test, a single stage, end suction centrifugal pump with 10 inch suction and discharge branches was chosen. In uncoated condition and running at 1300 rpm, the pump was found to deliver 875m³/hr at 26.5 meter head with an overall peak efficiency of 83.5%.

Testing of the same pump coated with Belzona 1341 (Supermetalgilde) gave a 6% increase at peak efficiency, resulting in a power reduction of 5.1kW at duty point. Assuming a 5,000 hour operating cycle/ annum, the power saving over this period would amount to 25,500kWhr.

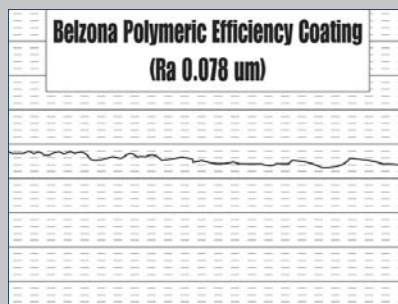

exact dimensions of badly eroded areas. Apart from offering excellent corrosion resistance, this material will significantly slow down erosion rates due to the high percentage of ceramic fillers in its composition.

In areas suffering severe damage (e.g. where part of the substrate has been removed by impact), a framework can be built to give mechanical strength back to the substrate. This framework can be built either by bolting or bonding on steel plates/gauze. The repair is then completed by filling the framework with the Belzona material to recreate the original profile.

Protection

To achieve complete protection from future damage, the component must be coated. Recognising the large variety of conditions (chemicals, temperatures, solids entrainment) under which different pumps operate, Belzona offers a wide range of liquid applied protection systems, which cover temperatures of up to 180°C and also resist a wide range of chemicals. Like Belzona repair materials, the Belzona coatings are VOC free, reducing health and safety concerns as well as avoiding product shrinkage commonly associated with many other coating technologies. Additionally, in contrast to many other coatings which need to be applied in a thick layer, Belzona coating systems are relatively thin and will not form any flow restrictions.

The material most commonly used in conjunction with Belzona 1311 (Ceramic R-Metal) is Belzona 1321 (Ceramic S-Metal), a durable protective coating with excellent resistance to erosion-corrosion in continuous immersion situations at temperatures of up to 60°C.

Where aggressive chemicals are present, the high-performance barrier coating Belzona 4311 (Magma CR1) is ideally suited to protect surfaces against the effects of chemical attack, in particular from acids and alkalis.

Other Belzona coating systems have been specifically designed for ultra-high temperature resistance, resistance to hot inorganic acids, high cavitation resistance or to provide protection against highly abrasive particles.

The range of durable protective coatings is complemented by Belzona 1341 (Supermetalgilde), a special high-performance coating system that can improve pump efficiency. Due to its ultra-smooth, self-levelling and hydrophobic properties as well as its low surface energy, it has been proven in independent tests to reduce turbulence and surface tension. At the same time, the coating will protect the component against future corrosion, meaning that its immediate effects on performance will be maintained over a long period, reducing power consumption and saving operating costs.

Having proven its benefits for used pumps, Belzona 1341 (Supermetalgilde) is also used by an increasing number of customers on new equipment to prolong service life and save

on energy costs. It is also becoming more common practice to coat new equipment with Belzona 1341 (Supermetalgilde) to avoid lengthy fine machining and polishing time when the construction does not meet the original design specification in terms of efficiency.

For details on the performance of Belzona 1341 (Supermetalgilde) on new pumps, please see the info box below. ■



Diffuser vanes with steel gauze in place Completed application



Typical effects of erosion-corrosion on a centrifugal pump cutwater After rebuilding and coating with Belzona



Thorough inspection for salt contamination (including chloride concentration measurement) ensures optimum surface preparation



Belzona 1341 (Supermetalgilde) used by an OEM



TOUGH AGAINST WEAR

Service life of 10 vacuum pumps increased by a factor of 6

In the following case study, a major paper company was looking for a solution to combat severe wear in 10 Siemens liquid ring vacuum pumps. The pumps had been in operation for approximately 12 months and had suffered significant loss in performance.

Upon dismantling one of the pumps, it was found that excessive carry over from the process had caused major erosion and corrosion damage to the pump components and that the critical tolerances had been lost.

Belzona Solution

With regards to the rotor, it was decided to utilise Belzona 1311 (Ceramic R-Metal) and Belzona 1321 (Ceramic S-Metal) to eliminate the

corrosion attack and greatly reduce the rate of erosion. For the rotor port plates, Belzona 1111 (Super Metal) was used for rebuilding and then machined to restore the critical tolerances.

An internal inspection of the pump after 13 months in service proved the Belzona material was in excellent condition and still providing complete protection to the pump. It should be noted that no changes in the process had occurred and that an unprotected pump was almost destroyed in less than 12 months. All 10 pumps in the plant have been repaired and coated with Belzona and remain in service for an average of 6 years before requiring overhaul. Thanks to the Belzona solution, the plant operator could completely avoid replacement of the pumps. ■



Measurement of intact pump vane



Measurement of worn vane



Rotor before application of the Belzona 1311 (Ceramic R-Metal) and Belzona 1321 (Ceramic S-Metal) system



After application of the Belzona 1311 (Ceramic R-Metal) and Belzona 1321 (Ceramic S-Metal) system



Port plate before application with Belzona 1111 (Super Metal)

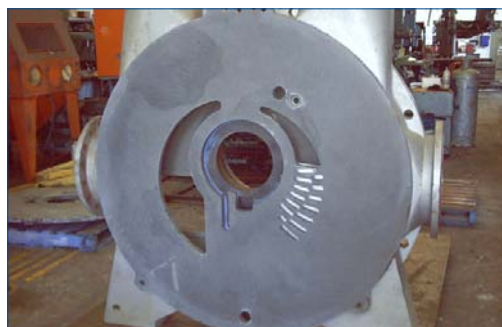

After application of Belzona 1111 (Super Metal)

BELZONA EFFICIENCY COATING

Belzona 1341 (Supermetalglide) was first formulated in 1989 in response to a market demand for a coating that makes pumps more efficient, increases their service life, while at the same time reducing the need for routine maintenance.

As a result, a hydrophobic coating was designed that inhibits corrosion, slows down erosion and improves the fluid flow.



Belzona 1341 (Supermetalglide) is:

Simple

- » Brush or spray applied
- » Long working life after mixing
- » Mix and use only what is needed

Safe

- » Low temperature cure ensures no fire risk
- » Environmentally friendly
- » Suitable for contact with potable water
- » Solvent free

Versatile

- » Overcoating time up to 24 hours after application
- » Use in water up to 60°C (140°F)

Effective

- » Outstanding adhesion
- » Good cavitation resistance
- » Excellent chemical resistance
- » Good abrasion properties
- » Improved hydrodynamic performance
- » Proven to be 15 times smoother than polished stainless steel

FURTHER BELZONA SOLUTIONS FOR PUMPS

Belzona offers repair, rebuilding and protection solutions for a wide variety of pump types and components. Some of the most common applications include:

- » General erosion-corrosion damage
- » Efficiency coatings
- » Bearing and packing seats
- » Water-lubricated bearings
- » Repairing and protecting impellers
- » Worn cutwater profiles
- » Eroded flow straighteners
- » Impeller wear ring clearances
- » Casting lobes
- » Cone clearances
- » Casings
- » Rotors
- » Valve plates and end covers



Belzona is not just a product manufacturer but strives to provide a complete supply and apply package through its Global Distribution network. This network was specifically created to provide clients with direct access to Belzona quality products, specialist application services, inspection services and supervision. It is Belzona's mission to meet specialist repair and maintenance needs in its target industries and markets worldwide.

GOING WITH THE FLOW

Flow rate increase in centrifugal pump maintained at 9.5% after 3½ years in service

The water supply company in this example had to deal with a problem of two badly corroded/cavitated centrifugal KSB water supply pumps, whose output had drastically decreased by 11%. In addition to erosion caused by cavitation, general and bi-metallic corrosion had caused leakage at the wear rings, which contributed to the significant loss in efficiency.



Corroded and cavitated pump

It was decided to restore the neck ring seats by a forming technique, using the neck rings as formers. First, the interior of the cast iron pump was grit blasted to the required surface preparation standard and the neck rings treated with release agent so that they could later be removed. Next, Belzona 1111 (Super Metal) was gradually built up on the prepared neck ring area. Immediately afterwards, the impeller of the pump (including the released neck rings) was lowered into position and all excess Belzona material that exuded from beneath the forming surfaces was removed. Correct height and alignment of the forming part is ensured by the correctly mounted and positioned bearings.

The same technique was then used to repair the other half of the casing. After cure, the impeller was removed and the repair dressed.

Finally, the pump was coated with Belzona 1341 (Supermetalgilde) to prevent corrosion and slow down future erosion damage. The result: The flow rate of the repaired pump was now 540l/sec, an increase of more than 12% over the corroded pump.

3½ years after the application, the pump was inspected and the flow rate was still found to be 530 l/sec, an increase of more than 9.5% over the corroded pump. ■

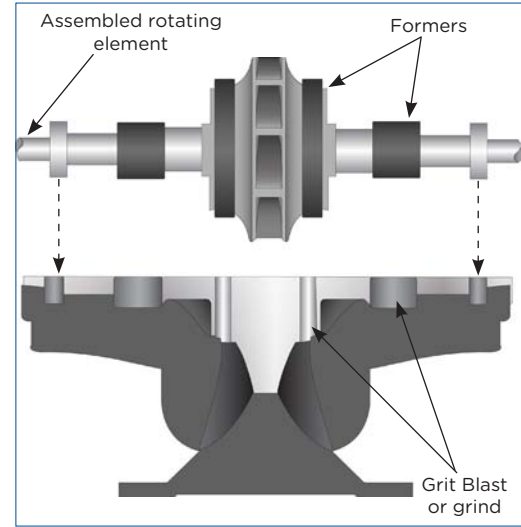

Completed repair

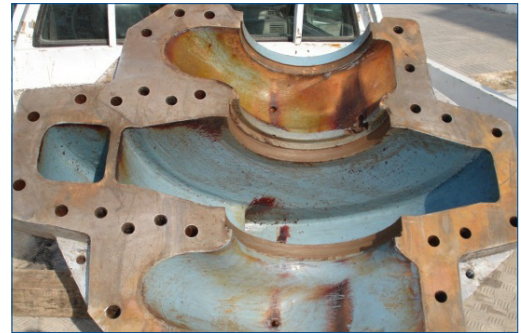

Coating in good condition after 3½ years in service

For more information, please contact your local Belzona representative:

BELZONA
 Repair • Protect • Improve

Issue No.

01

Spring 2013